



3nh Global

BENCHTOP SPECTROPHOTOMETER YS6002-M

Support transmittance, haze, yellowness, whiteness, etc. measurement,
new national standard pharmacopoeia color measurement



7in color touch screen



Concave grating

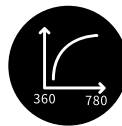

360-780nm full spectrum

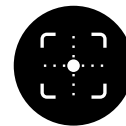

Camera positioning

It is widely used in haze analysis and transmittance test in the national standard pharmacopoeia color measurement, glass processing, plastic processing, film, display screen processing, packaging industry, liquid chemical analysis and other industries, and supports trace transmission measurement.



1. Instrument display

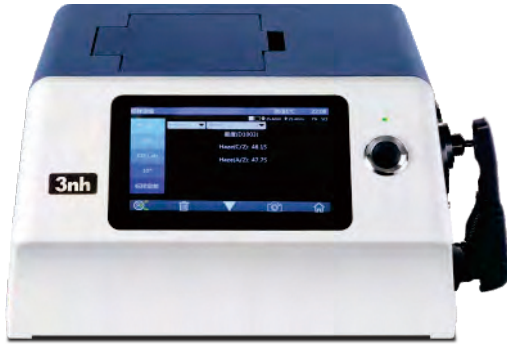

▲ Front



▲ Back

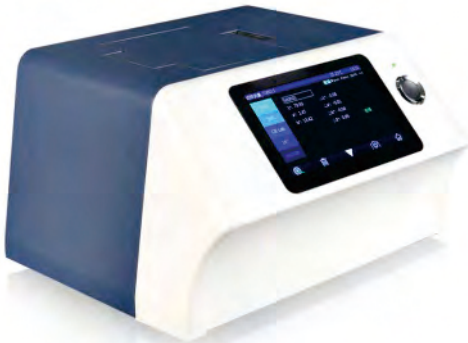

▲ Left side



▲ Right side

2. Instrument introduction

YS6002-M Benchtop Spectrophotometer meets the transmission D/0 (diffuse illumination, 0° direction reception) geometric optical structure specified by CIE15 (can also achieve approximate transmission 0/0 (parallel light illumination/0° reception) geometrical optics). The illumination light source of the instrument is a 360-780nm composite full-spectrum LED light source (D65), and the spectrum acquisition at intervals of 10nm is achieved through a precision concave grating and a 256-pixel CMOS detector. Accurate testing of various optical indicators (haze, transmittance, chromaticity, chromatic aberration, yellowness, whiteness, cobalt platinum index, Gardner index, etc.)

3. Instrument Features

1. High hardware configuration

YS6002-M adopts 7in TFT pure color capacitive touch screen, easy to operate; large storage space, can store more than 20,000 pieces of data at most, and is equipped with concave grating for spectroscopic, more accurate measurement;



2. High optical configuration

154mm integrating sphere, concave grating, 256-pixel CMOS detector, dual optical paths with high optical resolution.

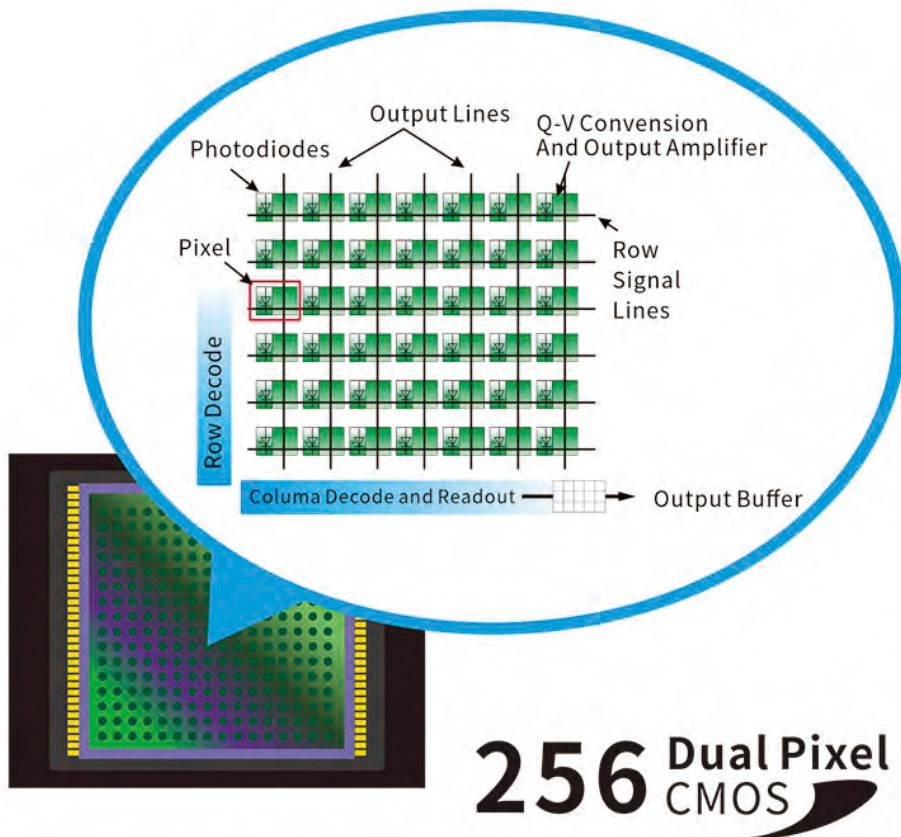

3. Using combined full-spectrum LED light source and UV light source

Adopt 360~780 full-spectrum combined LED light source with long life and low power consumption (close to D65 light source spectrum);

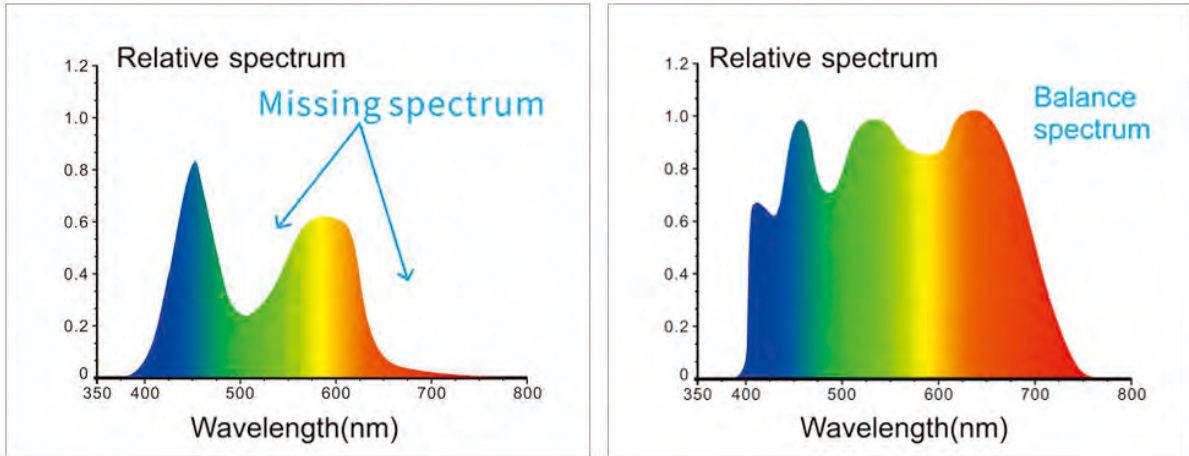

4. Various measurement indicators

Easily achieve accurate testing of C/A/D65 light source haze (ASTM D1003/1044), transmittance, cobalt platinum index, and Gardner index;

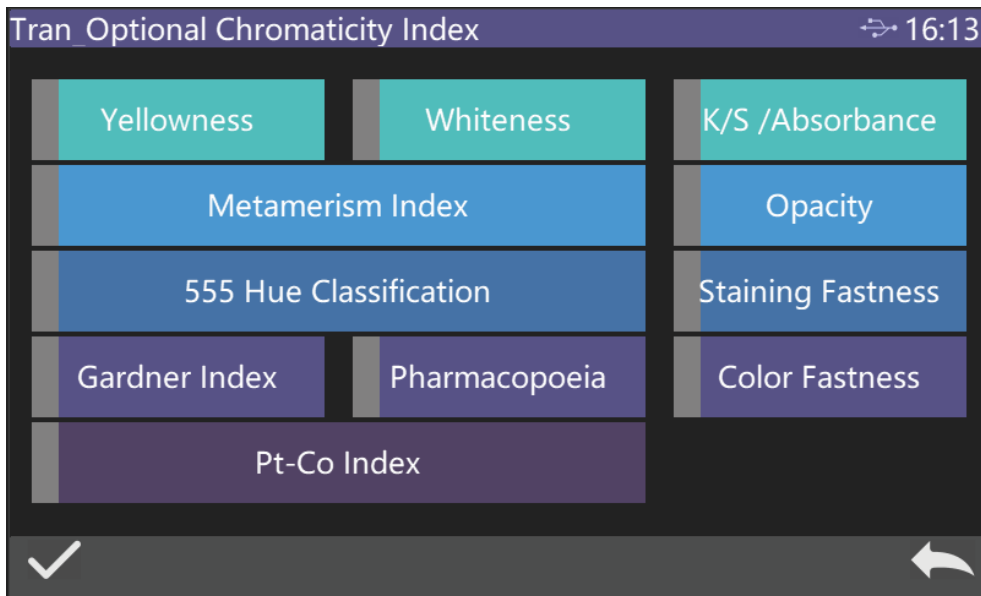

5. Multiple test modes

Support quality management mode and sample mode to meet the needs of more customers;

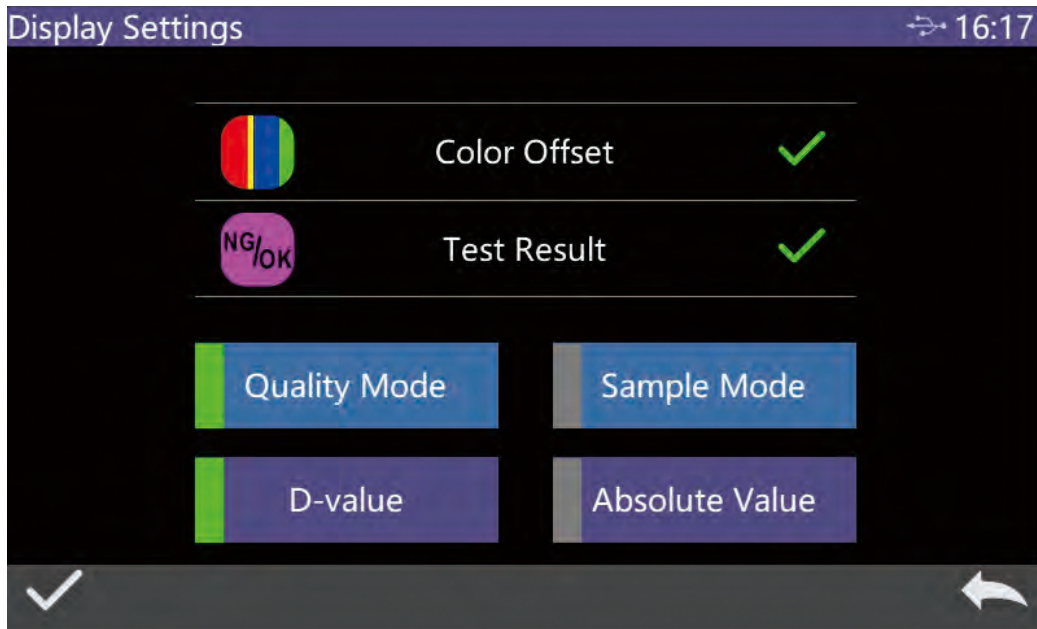

6. Measurement environment monitoring system

Independent light source detector and temperature sensor, constantly monitor light source and environmental changes to ensure reliable test data;

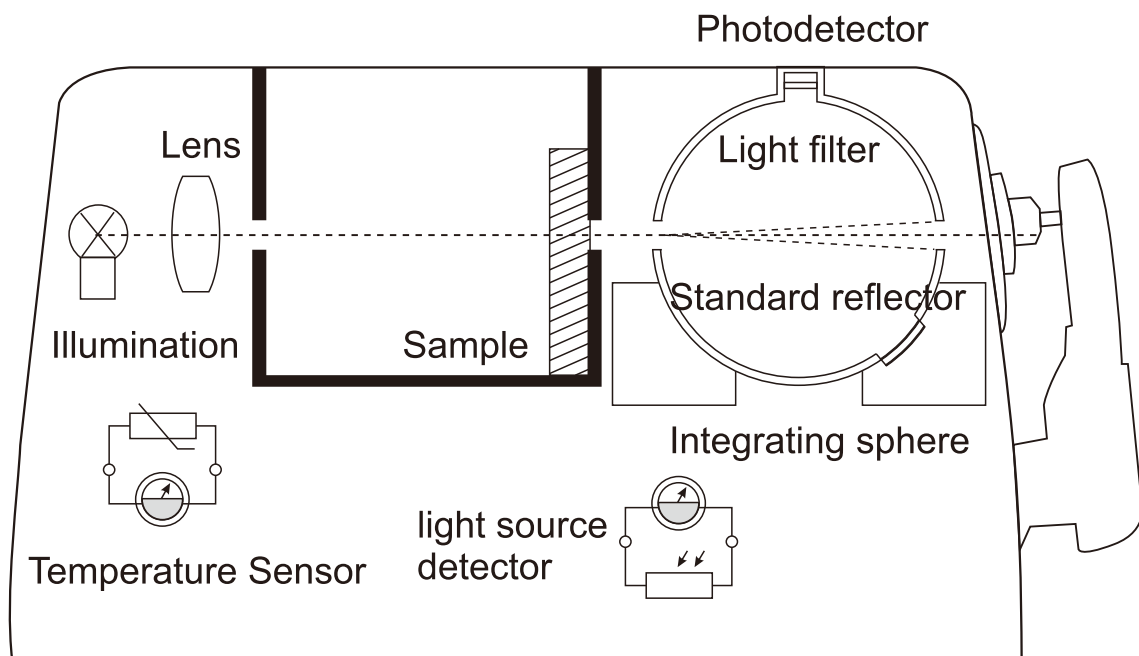

BENCHTOP SPECTROPHOTOMETER YS6002-M

7.a variety of light sources and color space options

Two standard observer angles of 2°/10°, a variety of light source modes, a variety of color systems, and a variety of standard chromaticity indicators to meet the needs of various customers for chromaticity testing;

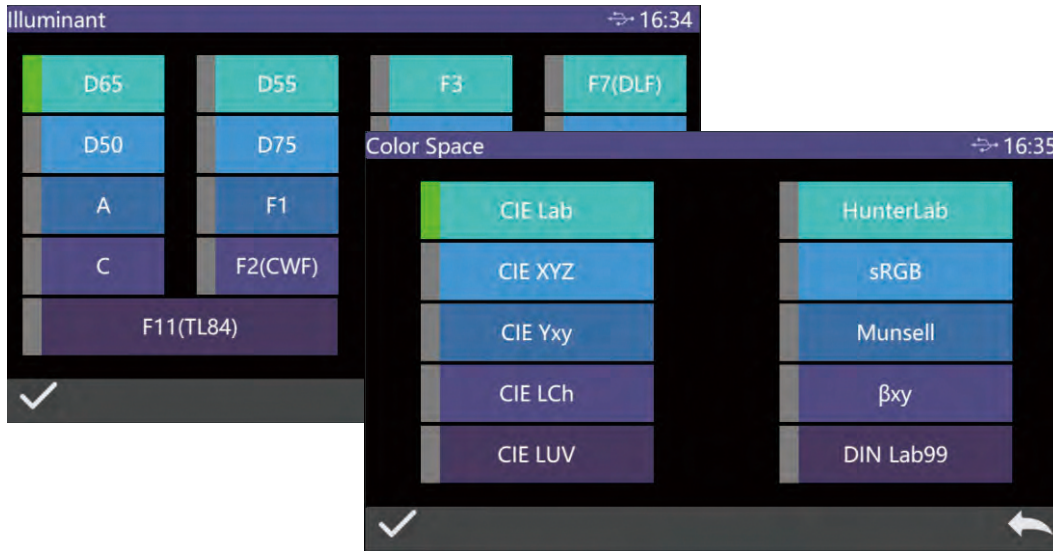

8. The PC-side software has powerful function expansion;

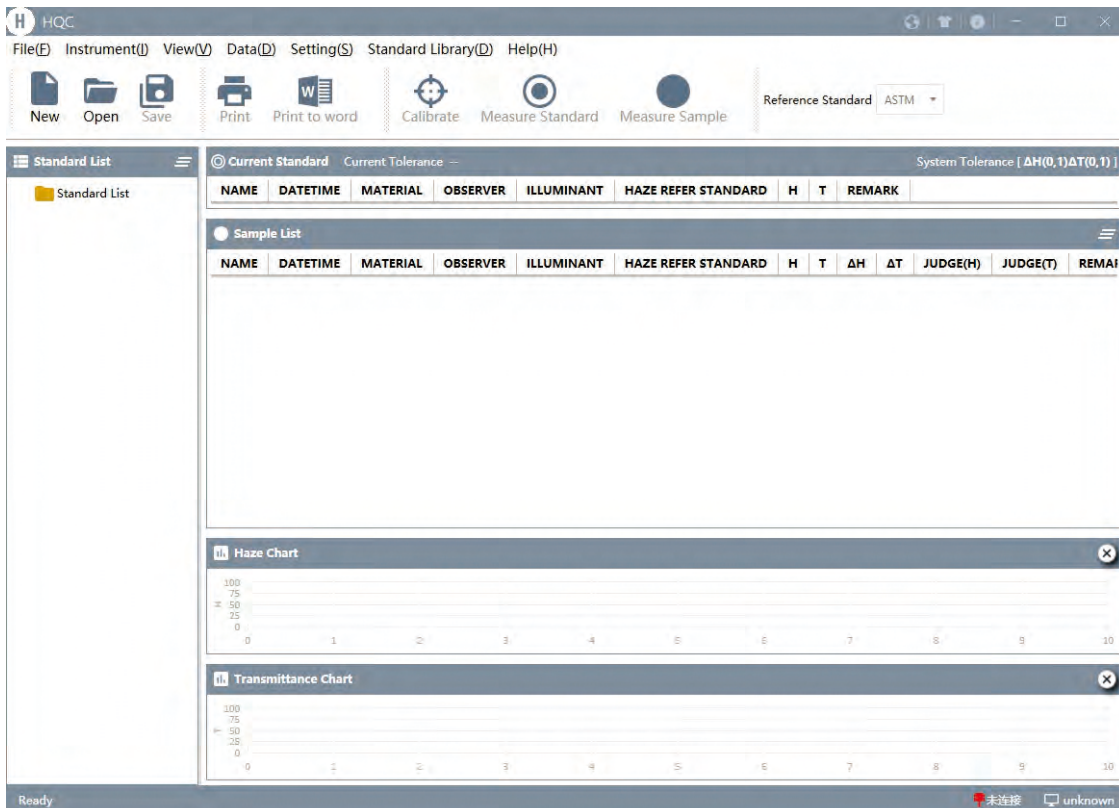

4. Application

It is widely used in haze analysis and transmittance test in the national standard pharmacopoeia color measurement, glass processing, plastic processing, film, display screen processing, packaging industry, liquid medicine analysis and other industries, and supports trace transmission measurement.

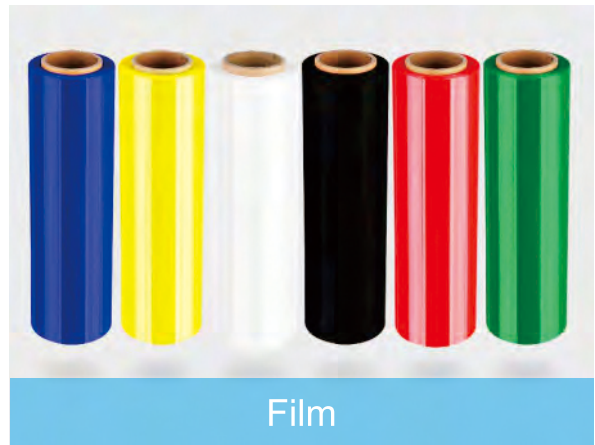
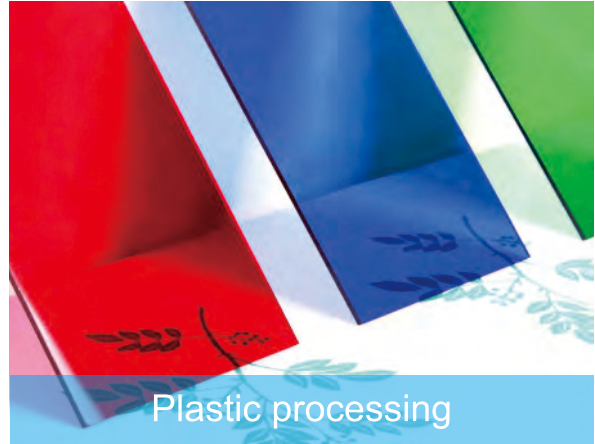

BENCHTOP SPECTROPHOTOMETER YS6002-M

5. Packing list

【Standard accessories】

Benchtop Spectrophotometer

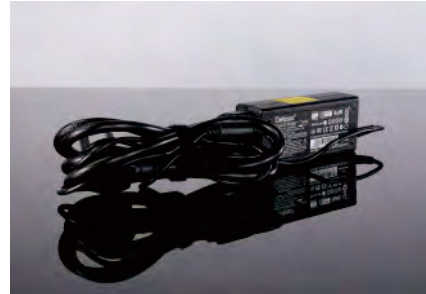

Power Adapter

Measuring diameter $\Phi 25.4\text{mm}$



USB cable



Manual



Certificate
Warranty Card



Calibrate the
whiteboard/black tube



Transmission black baffle



Sample holder



Transmission dish

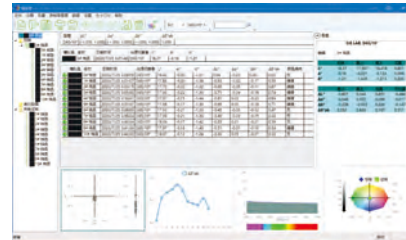

Computer software
(download from official website)

【Optional accessories (sold separately)】



Micro printer

6. Product parameters

Model: YS6002-M

Illumination mode: transmission: D/0 (diffuse illumination, 0° direction reception); approximately CIE15 stipulates 0/0 (parallel light illumination/0° reception);

Standard: ASTM D1003/1044, CIE No.15, GB/T 3978, GB 2893, GB/T 18833, ASTM E308, DIN5033 Teil7

Integrating Sphere Size: Φ154mm

Light Source: 360 nm to 780 nm, Combined LED Light

Spectrophotometric Mode: Concave Grating

Sensor: 256 Image Element Double Array CMOS Image Sensor

Wavelength Interval: 10nm

Semiband Width: 10nm

Measured Reflectance Range: 0-200%

Measuring Aperture: Transmissive: Φ25.4mm, Φ4mm

Color SpaceCIE: LAB,XYZ,Yxy,LCh,CIE LUV,Musell,s-RGB,HunterLab,βxy,DIN Lab99

Color Difference Formula: $\Delta E^*ab, \Delta E^*uv, \Delta E^*94, \Delta E^*cmc(2:1), \Delta E^*cmc(1:1), \Delta E^*00, \Delta E^*99, \Delta E^*(Hunter)$

Other Colorimetric Index: Haze (ASTM D1003/1044), Transmittance T, WI (ASTM E313, CIE/ISO, AATCC, Hunter), YI (ASTM D1925, ASTM 313), TI (ASTM E313, CIE/ISO), Metamerism Index Mt, Color fastness, color fastness, absorbance, APHA/Hazen/Pt-Co (platinum cobalt index), Gardner index, Saybolt (Seibert index), ASTM D1500 color scale, Chinese Pharmacopoeia chromaticity

Observer Angle: 2°/10°

Illuminant: D65,A,C,D50,D55,D75,F1,F2,F3,F4,F5,F6,F7,F8,F9,F10,F11,F12,CWF,DLF,TL83,TL84,TPL5,U30

Displayed Data: Spectrogram/values, Samples Chromaticity Values, Color Difference Values/graph, Pass/fail Result, Color Offset

Measuring Time: About 1.5s

Repeatability: Spectral transmittance: within 0.05% of standard deviation of test transmission reference white (400~700nm: within 0.04%); Chromaticity value: 25.4mm, within ΔE^*ab 0.03 (after the instrument is warmed up and calibrated, the average value of the transmission reference white is measured 30 times at an interval of 5s)

Inter-instrument Error: 25.4mm, within E^*ab 0.2 (the average value of the original 5 standard transmission color plates)

Dimension: L*W*H=370x300x200mm

Weight: Approx. 9.6kg

Power: AC 24V, 3A Power adapter power supply

Illuminant Life Span: 5 years, more than 3 million times measurements

Display: 7-inch TFT color LCD, Capacitive Touch Screen

Data Port: USB, Print serial port

Data Storage: Standard 5000 Pcs, Sample 20000 Pcs

Language: Simplified Chinese, Traditional Chinese, English

Standard accessories: power adapter, manual, quality management software (download from official website), data cable, reflection whiteboard, reflection black tube, transmission blackboard, 25.4 aperture, transmission test fixture assembly, micro-hole (4mm) transmission test fixture assembly

GUANGDONG THREE NH TECHNOLOGY CO., LTD.



Spectrophotometers



Colorimeters



Haze Meters



Gloss Meters



Test Charts



Light Booths

★ CONTACT US

🌐 web:www.3nh.com

✉ Email:3nh@3nh.com

☎ Tel:0086-020-82880288

📍 Add: 6-8th floors, Building B33, Low Carbon Headquarters Park, Xincheng Road No.400, Zengcheng District, Guangzhou, Guangdong Province, China